

2V164I Software

Voltage Regulating & Control Relay

relay monitoring systems pty ltd

Advanced Protection Devices



User Guide



Test Manual



Relay Software



µMATRIXwin

2V164I Relay Software

Links to Other Documents

User Guide: http://www.rmspl.com.au/userguide/2V164_user_guide.pdf

Software Downloads: <http://www.rmspl.com.au/digital/uMATRIX.htm>

Version Control

Issue	Date	Summary of changes
A	30/05/2003	Initial issue.
B	29/04/2003	Correct undervoltage alarm and blocking set points.
C	09/07/2003	UMX updated

Due to RMS continuous product improvement policy this information is subject to change without notice.
This document is uncontrolled and subject to copyright.

Author	Checked & Registered	.pdf file created	Released
ARF	DG	DG	

3.0 DESCRIPTION – UMX2V164I.UMX

3.1 Standard Features

The 2V164 provides a range of standard features as described in the RMS Technical Bulletin that may be downloaded from:

www.rmspl.com.au/handbook/2v164.pdf

3.2 Special Features

The 2V164 I UMX is primarily for use with the RMS 1M122[A] Parallel Control Scheme.

3.2.1 Tap Change Feedback Mode

Status input 6 is used by the 2V164I UMX to detect if the 1M122[A] Parallel Control Sub Rack it is fitted to is set to MASTER or INDEPENDENT mode. The tap change feedback operates in two ways depending on the status of this input as follows:

1M122[A] Set to MASTER Mode

When a voltage error is detected, the 2V164 will trigger the Initial Delay Timer. The Initial Delay Timer will start counting down provided the Tap Change Feedback input is true.

A normally closed contact on the 2V165 Parallel Control Relay is used to provide this signal. When a tap change is in progress, the signal is removed causing the 2V164 interval time delay to pause until the tap change step is completed.

The control sequence is as follows:

1. A voltage deviation starts the 2V164 initial time delay provided the Tap Change Feedback input is true.
2. The time delay expires and a tap change “pulse” command is output by the 2V164.
3. The 2V165 detects that a tap change step is in progress and removes the tap change feedback signal.
4. The 2V164 interval time delay is displayed, but does not start counting down.
5. When the 2V165 signals the 2V164 that the previous tap change step is complete, the interval time delay is initiated.
6. Sequence 2 to 5 will repeat at the rate determined by the Interval timer setting until the sensed voltage falls back to within pre-set bandwidth limits.

The default Tap Change Feedback status input is “Apply Volts” to initiate the timer.

1M122[A] Set to INDEPENDENT Mode

1. A voltage deviation starts the initial time delay.
2. The time delay expires & a tap change command *pulse* is output.
3. The interval time delay will be paused until a signal is received from the TPI transducer confirming that a tap change event has occurred.
4. The interval time delay is initiated.
Sequence 2 to 4 will repeat at the rate determined by the Interval timer setting until the sensed voltage moves back to within pre-set bandwidth limits.

3.2.2 Tap Position Display

The tap position is always displayed on the DATA PAGE.

3.2.3 Tap Change Output Commands

The tap change output is signalled via a clean RAISE or LOWER contact pulse of user defined duration. The default duration is 2s.

3.2.4 Alternate LDC Setting Group

An alternate group (LDC 2) for LDC resistance and reactance settings may be entered into the LDC menu with this UMX. Status Input 5 (SI5 on the wiring diagram), is used to toggle between the LDC setting groups.

When the LDC 2 Group is selected output contact 7 will pick up to signal this operational mode.

When an LDC mode is selected (Other than OFF), the message:

**** LDC Group 1 ** or ** LDC Group 2 **** is displayed on the HMI as determined by the SI5 input status.

4.0 USER INTERFACE

Refer to the μ MATRIX Users Guide for detailed instructions on the operation of the user interface.

To download a PDF version of the guide:
www.rmspl.com.au/digital/uMATRIXInfo.pdf

To download further μ MATRIX software & documentation:
www.rmspl.com.au/uMATRIX.htm

5.0 LOAD SOFTWARE

This section requires at least the following:
A PC with Windows 98 or later and at least one COM port.
UMatrixWin software.
The correct serial cable.
The ability to interrogate the relay via the front panel buttons.
A general understanding of how UMX and UMP files work with the relay.

Settable parameters will be overwritten by loading a new UMX file. They can however, be saved to a UMP file and then returned to the relay later. To learn how to do this, refer to the uMatrix Userguide.

5.1 Loading the UMX

Before loading the UMX2V164I software, ensure that it is compatible with your hardware. Download the compatibility list from the RMS website at:

www.rmspl.com.au/digital/compatibility.pdf

Now ensure that the bios version in the relay matches the table in section 2.0 of this document. (If the bios version is different, you may not be able to load this UMX. Contact RMS for support.)

Load the UMX via the front panel COM port using the 'uMatrixWin' software. Now ensure that the UMX version matches the table in section 2.0.

To interrogate for versions, press 'SET' and 'DATA' buttons simultaneously, then select 'Version Page'. Alternatively, use uMatrixWin – Options – Utilities.

Check versions

5.2 Customer Default UMP

Load customer UMP file as per the Job Card. If no UMP file is requested, write N/A in check box.

UMP file name

The Relay is now ready for field use.

SOFTWARE INSTALLED BY :

DATE :

6.0 CONNECTION DIAGRAM

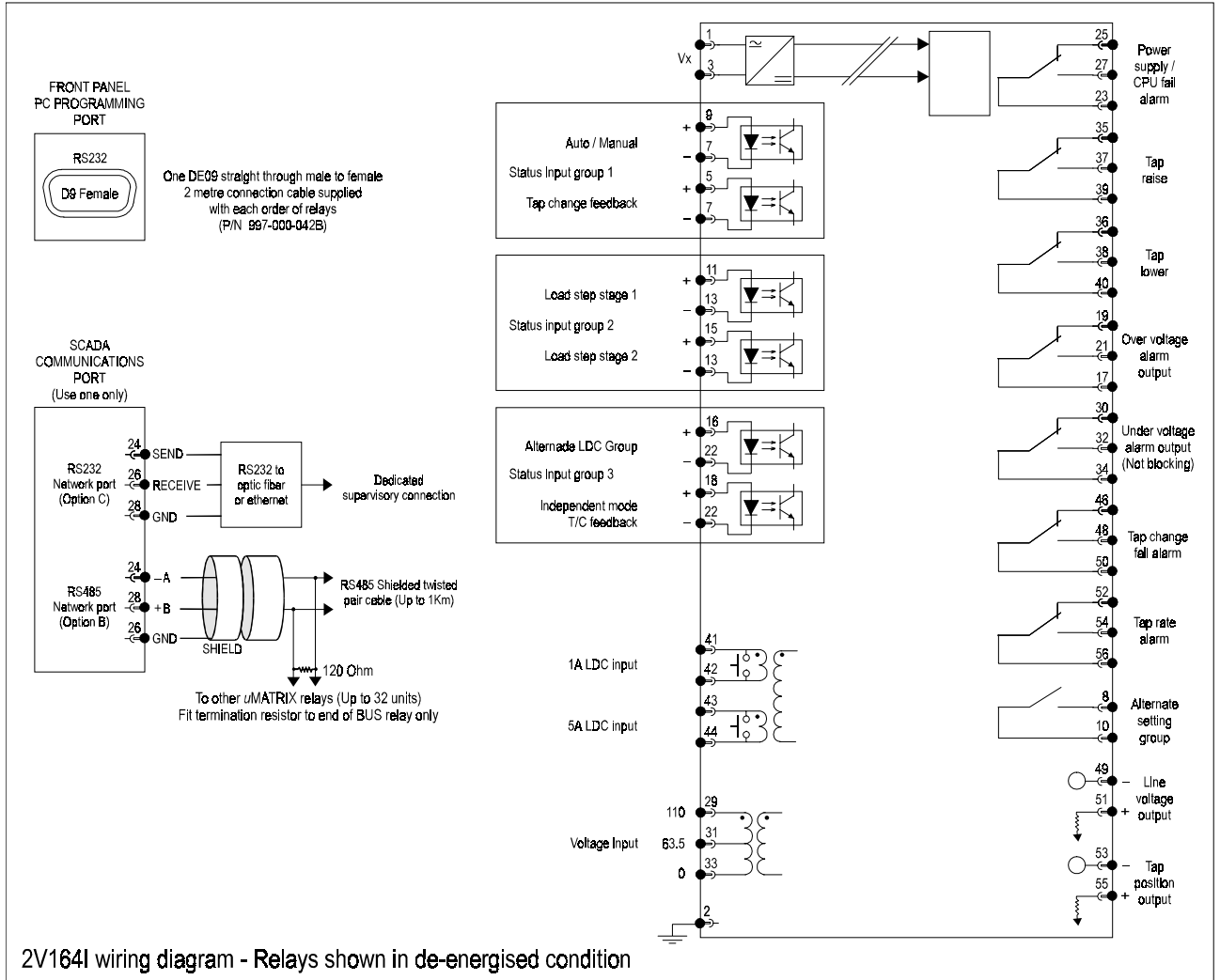

2V164I wiring diagram - Relays shown in de-energised condition

****DIAGNOSTIC PAGE****
 Versions Page:
 Temperature: 28.8oC
 ADC Voltages
 Frequencies & Phases
 Error Log
 Exit to Data Page

**** SET PAGE ****
 Set Point Menu
 Bandwidth Menu
 LDC Menu
 Tap Change Menu
 Comms Menu
 I/O Menu

**** AUTO ****
 LOAD SHED: - 5.0%
 Line Volts: 110.0V
 Line Amps: 5.0A
 Tap Posn : 15
**** LDC Group 1 ****
 INITIAL: 5.5s
 TARGET TIME: 30.0s

* RELAY PARAMETERS
 *
 * HAVE BEEN CHANGED
 *
 * PLEASE PRESS:
 *
 SELECT to save new
 DATA to discard new

**** VERSIONS PAGE****
 BIOS Version: V05.00
 S/W Version: V05.00
 CDB: RMS Default
 UMx: 2V164I
 S/N: 606576/01
 H/W Config: 23

(ADC VOLTAGES)
 Ch-0 122.60V - 4.23V
 Ch-1 4.76A - 4.76V
 Ch-2 15.55 - 3.50V
 Ch-3 Not Implemented
 Ch-4 Not Implemented
 Ch-5 Not Implemented
 Ch-6 Not Implemented
 Ch-7 28.8oC - 1.54V

FREQUENCY & PHASE
 Line V - 50.01 Hz
 Line I - 50.01 Hz
 Angle V-I - 11.3o

(ERROR LOG)
 ID: BIOS LINE: 268
 NO ENTRY
 NO ENTRY
 NO ENTRY
 NO ENTRY
 NO ENTRY

**** I/O MENU ****
 Input Settings
 Status Input Senses
 Output Settings
 Exit to Set Page

PROGRAM PORT MENU
 Baud Rate 19200
 Exit to Comms Menu

****COMMS MENU****
 Program Port Menu
 Network Port Menu
 Exit to Set Page

NETWORK PORT MENU
 Baud Rate 19200
 Parity NONE
 Data Bits 8
 Stop Bits 1
 Modbus Address 96
 Exit to Comms Menu

**** SET POINT MENU ****
 Set Point : 110.0V
 U/V Block : 90.0V
 U/V Delay : 2.0s
 O/V Alarm : 125.0V
 O/V Delay : 2.0s
 Exit to Set Page

**** FINE B/W MENU ****
 Bandwidth: 3.0V
 Initial: 30.0s
 Mode: Definite or Inverse
 Interval: 15.0s
 Coarse Bandwidth
 Exit to Set Page

****COARSE B/W MENU****
 Bandwidth : 10.0V
 Coarse Delay: 10.0s
 O/C Block : 150.0%
 O/C Delay : 10.0s
 Fine Bandwidth
 Exit to Set Page

**** LDC MENU ****
 LDC Mode : +Quad
 Resistance1: 5.0%
 Reactance1: 5.0%
 Resistance2: 5.0%
 Reactance2: 5.0%
 Exit to Set Page

**** T/C MENU ****
 Tap Rate : 100.00/Hr
 Reset Tap Log
 T/C Fail : 300.0s
 TPI Type : Analogue
 Max Taps: 22
 Exit to Set Page

**** INPUT SETTINGS ****
 VT Primary: 0.11kV
 CT Primary: 1A
 Load Step 1:- 5.0%
 Load Step 2:- 10.0%
 Exit to I/O Menu

**** STATUS INPUTS ****
 T/C Feedback: App V
 Auto/Manual : App V
 Load Step 1 : App V
 Load Step 2 : App V
 Inputs 5-7
 Exit to I/O Menu

**** STATUS INPUTS ****
 LDC Group 2 : App V
 Indep Mode : App V
 Input 7 : Rem V
 Inputs 1-4
 Exit to I/O Menu

**** OUTPUT SETTINGS ****
 Out 20mA @: 130.0V
 Out 4mA @: 90.0V
 T/C Pulse: 2.0s
 Exit to I/O Menu

Amendments	



2V164I (PULSE FEEDBACK, PULSE T/C)
MENU STRUCTURE

DRAWN	DATE	D/O CHECK	DATE	APPV CHECK	DATE	DRAWING NUMBER	ISSUE
D.W.B	19-Jun-2003					2V164_I_MENU_103	
DATE: 19-Jun-2003	TIME: 16:30:39						ISSUE DATE
FILE NAME: D:\THE_CHIP\RMS\MATRIX\SPECS\2V164\2V164 I MENU_103.sch							N.I.
SHEET:	SCALE:	CURRENT CN	SHEET: 1	OF: 1			