



Order Number

Serial Number

PRODUCT/TEST MANUAL

1M333K1

DEFINITE TIME UNDER FREQUENCY RACK

Issue Level	Date	Summary of changes
A	19/07/1996	Initial issue.

Due to RMS continuous product improvement policy this information is subject to change without notice.
This document is uncontrolled and subject to copyright.

Author	Checked & Registered	.pdf file created	Released
ERL	MW	MW	

1. BROAD DESCRIPTION

The 1M333K1 consists of three digitally set definite time underfrequency modules (2H33's) utilising a crystal oscillator for both frequency measuring and time delay functions. The three modules are presented in a 3U 483 mm sub rack for ease of rack mounting. Harmonics on the input are attenuated by an active bandpass filter and analog circuitry is also used to provide an undervoltage lockout function. The remaining circuitry is CMOS digital and both frequency level and time delay are set on thumbwheel switches mounted on the front dial of the unit. Operation of the high power output relay is flagged with a bistable magnetic disc flag and the output relay will self-reset if a digitally presettable number of "good" input cycles have occurred.

2. SPECIFICATIONS - each module

Frequency Sensing Circuitry Characteristics

Operational Setting Range	15.00 to 22.50ms period (ie. 66.67 to 44.44 Hertz) Thumbwheel switch selection with 0.01ms resolution
Accuracy	$\pm 0.05\%$ of setting
Repeatability	± 0.01 ms
Hysteresis	Less than 0.05ms
Response Time	100ms (approx). Dependent on input frequency and degree and rate of frequency shift.
Sensing Supply	110V AC nominal (140V AC max. continuous)
Sensing Supply Burden	Less than 2VA at nominal
Undervoltage Lockout	Preset at 50% of nominal. (May be internally adjusted within the range 30% to 60% of nominal.)

Timer Circuitry Characteristics

Operation Setting Range	0.05 to 9.99 Sec. Thumbwheel switch selection with 0.01 Sec. resolution. Caution should be exercised when setting below 0.05 Sec. as instability may occur under certain conditions.
Accuracy	$\pm 1\%$ of setting, +20ms -0ms
Repeatability	Less than 0.01 Sec.
Reset Time	Internal DIL Switch selection of from 1 to 9 "good" input cycles to elapse before timer resets.

2. SPECIFICATIONS (Cont)

Auxiliary Supply	50 VDC
Auxiliary Supply Range	-25% to +20%
Auxiliary Supply Burden	10 Watt (110V unit)
Ambient Temperature Range	-5°C to +55°C
Output Relay Contact Ratings	

Make and Carry Continuously

1650 VA AC resistive with maximums of 240 Volt and 7.5 Amp
 300 W DC resistive with maximums of 125 Volt and 2.5 Amp

AC Break Capacity

1650 VA AC resistive with maximums of 240 Volt and 7.5 Amp

DC Break Capacity (Amps)

Voltage		24V	48V	125V	250V
Resistive rating		10	2	.6	.5

3. TEST EQUIPMENT REQUIRED

- 50 Volt DC Supply
- 110 Volt AC Supply
- Digital Frequency Meter
- Digital Voltmeter
- Digital Storage Oscilloscope

4. ASSOCIATED DRAWINGS

- 157-333-101 External wiring Diagram
- 169-033-201 Master Circuit Diagram
- 660-099-401 PCB Loading - Analogue Section
- 660-100-401 PCB Loading - Digital Section
- 660-129-401 PCB Loading - Thumbwheel Switch Mtg.

5.0 HIGH VOLTAGE TESTING

These tests apply to the three modules inserted in the rack and tested as a complete unit.

- a) Apply 3 5KV 1/50 impulses of each polarity between terminal groups as listed in A & B below.
- b) Apply 2KV RMS between the terminal groups as listed in A & B below for 1 minute.

TERMINAL
 7 to 24
 7 to 30

TERMINAL
 25 to 30
 FRAME

6.0 CALIBRATION PROCEDURE

MODULE 1 SERIAL No <hr/>
--

6.1 Disassembly Procedure

Remove the front Polycarbonate cover to access the modules, withdraw the module from the rack.

To gain access to the non component sides of the analogue and digital circuit boards, the screws securing these assemblies to the front and rear panels must be removed, there are two lots of four screws to undo. This enables the desired board/rail assembly to be unplugged from the thumbwheel mounting PCB. Care should be exercised during this step to avoid damaging the Ferranti flag mechanism.

6.2 Undervoltage Lockout Calibration

- a) Apply auxiliary supply of 50 volts and check that 10 volt and 20 volt rail voltages are within +/- 10 percent of nominal.
- b) Monitoring test point 2 on the 660-099 PCB adjust trimpot R18 until the voltage just goes low when the AC voltage is reduced below 55 volts. (The filter switch should be in the "OUT" position.)
- c) Check that test point 2 switches cleanly as the AC voltage is increased above approximately 65 volts .

6.3 Bandpass Filter Operation

- a) Connect a dB (decibel) measuring DVM between IC1 pin 8 and the +10 volt rail.
- b) Check that for 110 volts AC in maximum amplitude on the DVM occurs within the range of 45-50 Hz. OK
- c) Check that at 30 Hz and 60 Hz that IC1-8 is more than 7db below amplitude at resonance.

6.4 Oscillator 1 Mhz

Connect a frequency counter to TP3 on PCB 660-100 and check that the frequency is within +/- 50 Hz of 1 Mhz.

OK

6.5 Frequency Measuring Clock Circuitry

- a) Connect the oscilloscope to TP4 and trigger input to IC3 pin 2. (Set trigger on the -ve going edge.)
- b) Set “period setting to 20.00 ms, “time” to 0.05 S and “cycles to reset” DIL switch to 4 cycles.
- c) Set AC input period to 20.01 ms and check that TP4 waveform is as shown on sheet 18 of the descriptive manual. Note that the observed waveform will jitter due to the non synchronism of AC input and clock waveforms. This waveform is best observed by storing a single sweep on a storage oscilloscope.
- d) Adjust the input period to 19.90ms and check that the three or four “hysteresis” pulses disappear for the overfrequency condition. (Output relay dropped out).

6.6 Period Setting Thumbwheel Switches

For the following settings record the input waveform period at which the output relay operates. Adjust frequency downwards (increasing period) To ensure that the hysteresis does not influence the results. Perform the tests at nominal AC and DC voltage levels.

Settings

SETTING	MINIMUM	MAXIMUM	NOMINAL	ACTUAL	UNITS
11.11	11.10	11.12	11.11		ms
12.22	12.21	12.23	12.22		ms
13.33	13.32	13.34	13.33		ms
14.44	14.43	14.45	14.44		ms
15.55	15.54	15.56	15.55		ms
16.66	16.65	16.67	16.66		ms
17.77	17.76	17.78	17.77		ms
18.88	18.87	18.89	18.88		ms
19.99	19.98	20.00	19.99		ms
20.00	19.99	20.01	20.00		ms

6.7 Timer Logic Check

Check that when the underfrequency condition is present a 10 ms period waveform appears at TP6 on 660-100 logic PCB.

OK

6.8 Timer Operational Check

- a) Adjust input frequency to 80Hz (12.5ms period) and set period setting to 10.00ms. Set AC & DC input voltages levels to nominal. Connect timing apparatus "power" contacts between 660-100 SK1 pins 6 & 24. When the contact is closed the 2H33 will effectively be set at 14.00ms and when open the setting will be 10.00ms as indicated.
- b) Measure the time interval between the opening of the "power" contact and the operation of the output relay contact. Note that the observed times will be 30 - 40 ms greater than the timer settings due to the operate time of the output relay and the response time of the frequency sensing circuitry.
- c) Record times for the following time settings.

SETTING	MINIMUM	MAXIMUM	NOMINAL	ACTUAL	UNIT
0.11	0.12	0.16	0.14		SEC
1.22	1.23	1.27	1.25		SEC
2.33	2.34	2.38	2.36		SEC
3.44	3.45	3.49	3.47		SEC
4.55	4.56	4.60	4.58		SEC
5.66	5.67	5.71	5.69		SEC
6.77	6.78	6.82	6.80		SEC
7.88	7.89	7.93	7.91		SEC
8.99	9.00	9.04	9.02		SEC
9.00	9.01	9.05	9.03		SEC

6.9 Cycles To Reset Timer

- a) Adjust input frequency to 50 Hz and set period setting to 15 ms. Set timer to 1.00 sec. Connect "power" contact of the timing apparatus between R25-D11 junction and SK1 pin 27 (on 660-100 PCB). The number of cycles to reset the timer will be the time interval between closure of the "power" contact and the dropout of the out put relay.
- b) Set "cycles to reset" DIL switch to 0111 (7 cycles) and record the time.

MINIMUM	MAXIMUM	NOMINAL	ACTUAL	UNIT
135	165	150		MS

6.9 Cycles To Reset Timer (Cont)

- c) 16 Set "cycles to reset" DIL switch to 1000 (8 cycles) and record time.

MINIMUM	MAXIMUM	NOMINAL	ACTUAL	UNIT
155	188	170		MS

6.0 CALIBRATION PROCEDURE

MODULE 2 SERIAL No <hr/>
--

6.1 Disassembly Procedure

Remove the front Polycarbonate cover to access the modules, withdraw the module from the rack.

To gain access to the non component sides of the analogue and digital circuit boards, the screws securing these assemblies to the front and rear panels must be removed, there are two lots of four screws to undo. This enables the desired board/rail assembly to be unplugged from the thumbwheel mounting PCB. Care should be exercised during this step to avoid damaging the Ferranti flag mechanism.

6.2 Undervoltage Lockout Calibration

- a) Apply auxiliary supply of 50 volts and check that 10 volt and 20 volt rail voltages are within +/- 10 percent of nominal.
- b) Monitoring test point 2 on the 660-099 PCB adjust trimpot R18 until the voltage just goes low when the AC voltage is reduced below 55 volts. (The filter switch should be in the "OUT" position.)
- d) Check that test point 2 switches cleanly as the AC voltage is increased above approximately 65 volts .

6.3 Bandpass Filter Operation

- a) Connect a dB (decibel) measuring DVM between IC1 pin 8 and the +10 volt rail.
- b) Check that for 110 volts AC in maximum amplitude on the DVM occurs within the range of 45-50 Hz. OK
- c) Check that at 30 Hz and 60 Hz that IC1-8 is more than 7db below amplitude at resonance.

6.4 Oscillator 1 Mhz

Connect a frequency counter to TP3 on PCB 660-100 and check that the frequency is within +/- 50 Hz of 1 Mhz.

OK

6.5 Frequency Measuring Clock Circuitry

- a) Connect the oscilloscope to TP4 and trigger input to IC3 pin 2. (Set trigger on the -ve going edge.)
- b) Set "period setting to 20.00 ms, "time" to 0.05 S and "cycles to reset" DIL switch to 4 cycles.
- c) Set AC input period to 20.01 ms and check that TP4 waveform is as shown on sheet 18 of the descriptive manual. Note that the observed waveform will jitter due to the non synchronism of AC input and clock waveforms. This waveform is best observed by storing a single sweep on a storage oscilloscope.
- d) Adjust the input period to 19.90ms and check that the three or four "hysteresis" pulses disappear for the overfrequency condition. (Output relay dropped out.)

6.6 Period Setting Thumbwheel Switches

For the following settings record the input waveform period at which the output relay operates. Adjust frequency downwards (increasing period) to ensure that the hysteresis does not influence the results. Perform the tests at nominal AC and DC voltage levels.

Settings

SETTING	MINIMUM	MAXIMUM	NOMINAL	ACTUAL	UNITS
11.11	11.10	11.12	11.11		ms
12.22	12.21	12.23	12.22		ms
13.33	13.32	13.34	13.33		ms
14.44	14.43	14.45	14.44		ms
15.55	15.54	15.56	15.55		ms
16.66	16.65	16.67	16.66		ms
17.77	17.76	17.78	17.77		ms
18.88	18.87	18.89	18.88		ms
19.99	19.98	20.00	19.99		ms
20.00	19.99	20.01	20.00		ms

6.7 Timer Logic Check

Check that when the underfrequency condition is present a 10 ms period waveform appears at TP6 on 660-100 logic PCB.

OK

6.8 Timer Operational Check

- a) Adjust input frequency to 80Hz (12.5ms period) and set period setting to 10.00ms. Set AC & DC input voltages levels to nominal. Connect timing apparatus “power” contacts between 660-100 SK1 pins 6 & 24. When the contact is closed the 2H33 will effectively be set at 14.00ms and when open the setting will be 10.00ms as indicated.
- b) Measure the time interval between the opening of the “power” contact and the operation of the output relay contact. Note that the observed times will be 30 - 40 ms greater than the timer settings due to the operate time of the output relay and the response time of the frequency sensing circuitry.
- c) Record times for the following time settings.

SETTING	MINIMUM	MAXIMUM	NOMINAL	ACTUAL	UNIT
0.11	0.12	0.16	0.14		SEC
1.22	1.23	1.27	1.25		SEC
2.33	2.34	2.38	2.36		SEC
3.44	3.45	3.49	3.47		SEC
4.55	4.56	4.60	4.58		SEC
5.66	5.67	5.71	5.69		SEC
6.77	6.78	6.82	6.80		SEC
7.88	7.89	7.93	7.91		SEC
8.99	9.00	9.04	9.02		SEC
9.00	9.01	9.05	9.03		SEC

6.9 Cycles To Reset Timer

- a) Adjust input frequency to 50 Hz and set period setting to 15 ms. Set timer to 1.00 sec. Connect “power” contact of the timing apparatus between R25-D11 junction and SK1 pin 27 (on 660-100 PCB). The number of cycles to reset the timer will be the time interval between closure of the “power” contact and the dropout of the out put relay.
- b) Set “cycles to reset” DIL switch to 0111 (7 cycles) and record the time.

MINIMUM	MAXIMUM	NOMINAL	ACTUAL	UNIT
135	165	150		MS

6.9 Cycles To Reset Timer (Cont)

- c) 16 Set “cycles to reset” DIL switch to 1000 (8 cycles) and record time.

MINIMUM	MAXIMUM	NOMINAL	ACTUAL	UNIT
155	188	170		MS

6.0 CALIBRATION PROCEDURE

MODULE 3 SERIAL No <hr/>
--

6.1 Disassembly Procedure

Remove the front Polycarbonate cover to access the modules, withdraw the module from the rack.

To gain access to the non component sides of the analogue and digital circuit boards, the screws securing these assemblies to the front and rear panels must be removed, there are two lots of four screws to undo. This enables the desired board/rail assembly to be unplugged from the thumbwheel mounting PCB. Care should be exercised during this step to avoid damaging the Ferranti flag mechanism.

6.2 Undervoltage Lockout Calibration

- a) Apply auxiliary supply of 50 volts and check that 10 volt and 20 volt rail voltages are within +/- 10 percent of nominal.
- b) Monitoring test point 2 on the 660-099 PCB adjust trimpot R18 until the voltage just goes low when the AC voltage is reduced below 55 volts. (The filter switch should be in the "OUT" position.)
- c) Check that test point 2 switches cleanly as the AC voltage is increased above approximately 65 volts .

6.3 Bandpass Filter Operation

- a) Connect a dB (decibel) measuring DVM between IC1 pin 8 and the +10 volt rail.
- b) Check that for 110 volts AC in maximum amplitude on the DVM occurs within the range of 45-50 Hz.
OK
- c) Check that at 30 Hz and 60 Hz that IC1-8 is more than 7db below amplitude at resonance.

6.4 Oscillator 1 Mhz

Connect a frequency counter to TP3 on PCB 660-100 and check that the frequency is within +/- 50 Hz of 1 Mhz.

OK

6.5 Frequency Measuring Clock Circuitry

- a) Connect the oscilloscope to TP4 and trigger input to IC3 pin 2. (Set trigger on the -ve going edge.)
- b) Set “period setting to 20.00 ms, “time” to 0.05 S and “cycles to reset” DIL switch to 4 cycles.
- c) Set AC input period to 20.01 ms and check that TP4 waveform is as shown on sheet 18 of the descriptive manual. Note that the observed waveform will jitter due to the non synchronism of AC input and clock waveforms. This waveform is best observed by storing a single sweep on a storage oscilloscope.
- d) Adjust the input period to 19.90ms and check that the three or four “hysteresis” pulses disappear for the overfrequency condition. (Output relay dropped out)

6.6 Period Setting Thumbwheel Switches

For the following settings record the input waveform period at which the output relay operates. Adjust frequency downwards (increasing period) to ensure that the hysteresis does not influence the results. Perform the tests at nominal AC and DC voltage levels.

Settings

SETTING	MINIMUM	MAXIMUM	NOMINAL	ACTUAL	UNITS
11.11	11.10	11.12	11.11		ms
12.22	12.21	12.23	12.22		ms
13.33	13.32	13.34	13.33		ms
14.44	14.43	14.45	14.44		ms
15.55	15.54	15.56	15.55		ms
16.66	16.65	16.67	16.66		ms
17.77	17.76	17.78	17.77		ms
18.88	18.87	18.89	18.88		ms
19.99	19.98	20.00	19.99		ms
20.00	19.99	20.01	20.00		ms

6.7 Timer Logic Check

Check that when the underfrequency condition is present a 10 ms period waveform appears at TP6 on 660-100 logic PCB.

OK

6.8 Timer Operational Check

- a) Adjust input frequency to 80Hz (12.5ms period) and set period setting to 10.00ms. Set AC & DC input voltages levels to nominal. Connect timing apparatus “power” contacts between 660-100 SK1 pins 6 & 24. When the contact is closed the 2H33 will effectively be set at 14.00ms and when open the setting will be 10.00ms as indicated.
- b) Measure the time interval between the opening of the “power” contact and the operation of the output relay contact. Note that the observed times will be 30 - 40 ms greater than the timer settings due to the operate time of the output relay and the response time of the frequency sensing circuitry.
- c) Record times for the following time settings.

SETTING	MINIMUM	MAXIMUM	NOMINAL	ACTUAL	UNIT
0.11	0.12	0.16	0.14		SEC
1.22	1.23	1.27	1.25		SEC
2.33	2.34	2.38	2.36		SEC
3.44	3.45	3.49	3.47		SEC
4.55	4.56	4.60	4.58		SEC
5.66	5.67	5.71	5.69		SEC
6.77	6.78	6.82	6.80		SEC
7.88	7.89	7.93	7.91		SEC
8.99	9.00	9.04	9.02		SEC
9.00	9.01	9.05	9.03		SEC

6.9 Cycles To Reset Timer

- a) Adjust input frequency to 50 Hz and set period setting to 15 ms. Set timer to 1.00 sec. Connect “power” contact of the timing apparatus between R25-D11 junction and SK1 pin 27 (on 660-100 PCB). The number of cycles to reset the timer will be the time interval between closure of the “power” contact and the dropout of the out put relay.
- b) Set “cycles to reset” DIL switch to 0111 (7 cycles) and record the time.

MINIMUM	MAXIMUM	NOMINAL	ACTUAL	UNIT
135	165	150		MS

6.9 Cycles To Reset Timer (Cont)

- c) 16 Set “cycles to reset” DIL switch to 1000 (8 cycles) and record time.

MINIMUM	MAXIMUM	NOMINAL	ACTUAL	UNIT
155	188	170		MS

7.0 GENERAL & FUNCTIONAL

Check that the relay is electrically sound and mechanically robust as per Standard Inspection & Test Schedule 903-000-026

PASS

TESTED BY : _____ DATE : _____

8.0 CONNECTION DIAGRAM

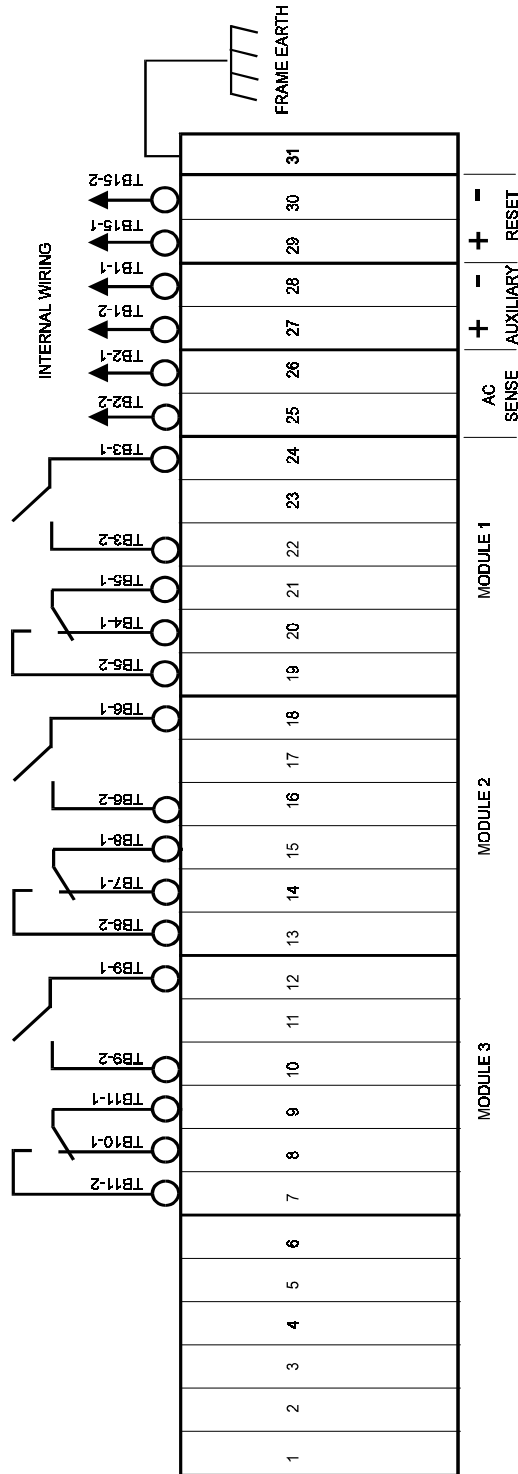

○ Denotes connection on 660-276-1 Motherboard