

Features

- Suitable for interfacing to tap changers with binary or BCD TPI outputs
- Suitable for application with voltage divider TPI circuits (Resistor values in the range 20 - 400 ohms may be employed)
- 50V DC output drive circuit to improve contact whetting performance
- Frequency output immune to line disturbance
- Two core un-shielded cable between sender unit & 2V164
- Isolated power supply
- Plug in measuring module
- Double insulated high impact polystyrol case
- Termination socket included for surface mounting enabling front or rear connection with optional DIN rail mounting
- Simple & robust construction

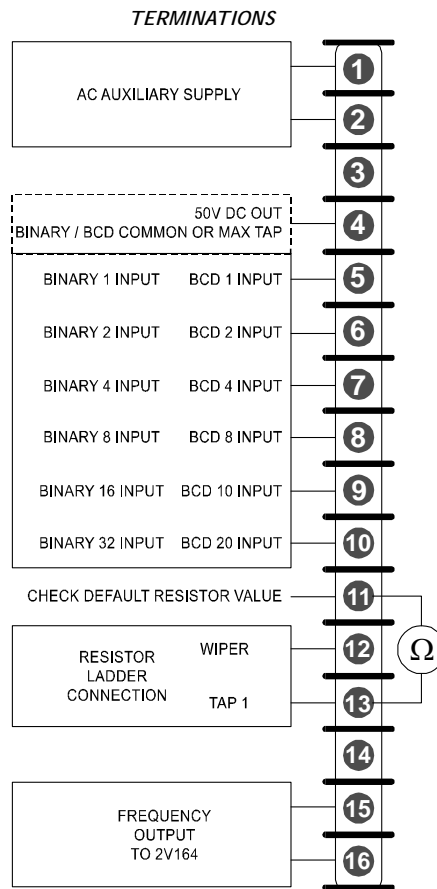

Description

Made in Australia

The 2V200 is specifically designed for operation with the RMS type 2V164 Voltage Regulating Relay (VRR) & application on power transformers fitted with on load tap changers. The 2V200 provides a noise immune interface between the tap changer & a remote tap position indicator (TPI), display.

The 2V200 is designed to interface with tap changers using either binary / BCD coded signals or a traditional voltage divider circuit. The 2V200 generates a 50V DC output to connect to the auxiliary contacts on the tap changer. These contacts are often prone to high resistance & voltages lower than 50V may prove unreliable due to low whetting currents.

The 2V200 converts the tap changer auxiliary contact inputs to a low frequency signal proportional to the tap position. The 2V164 VRR converts this frequency to a voltage signal through an optically isolated input which is then feed into an A-D converter. The tap position is displayed on the front panel of the 2V164 based on the pre-programmed maximum tap position.

The 2V164 optionally provides two independent analogue outputs proportional to the tap position & the line voltage. These 4-20mA outputs are intended for connection to a SCADA input or a local display.

TAP CHANGER INTERFACE – RESISTOR DIVIDER INPUT

Connect using 2V200 terminals 4, 12 & 13.

400 ohm Resistors

Recommended value for resistor Rs: 400 ohms
 Tolerance: 1%
 Power rating: 0.5W

Rs resistors are to be connected between adjacent taps as per the application diagram shown in figure 1. Where 400 ohm resistors are employed the padding resistor Rp is not required.

The RMS TPI Resistor Box type 4O200 is designed for this function & provides 0.5W 1% resistors to interface with tap changer auxiliary switches.

<400 ohm Resistors

Resistor (Rs) values less than 400 ohms (20 ohms minimum), may be employed provided the following two conditions are met:

A padding resistor Rp is fitted as per figure 1: $\frac{1}{R_p} = \frac{1}{R_s} - \frac{1}{400}$

The parallel resistance across Rp can be checked using an ohm meter across terminals 11 & 13 without the auxiliary supply applied. This value must be equal to the chosen value for Rs.

The total resistance between terminals 4 & 13 is ≥ 600 ohms.

The number of taps T x Rs is ≥ 600 ohms
 (E.g. 30 taps x 20 ohms per tap = 600 ohms)

If the value calculated above is < 600 ohms due to < 30 taps then an additional resistor (Ra) can be placed above the top tap resistor to terminal 4. Calculate Ra & re-check as follows:

$R_a = (30 - T) \times R_s$ & check that $T \times R_s + R_a$ is ≥ 600 ohms

The 2V164 / 2V165 relays must always be set for ANALOGUE TPI operation with the number of taps set to 30 when Ra is added to the circuit.

2V164 Voltage Regulator Relay Configuration

The 2V164 / 2V165 relays must be programmed for ANALOGUE TPI operation & the number of tap positions T, within the range 10 to 30 entered. Scaling is carried out automatically within the 2V164 so that the correct tap position is indicated on the data display.

TAP CHANGER INTERFACE – BINARY OR BCD INPUT

The connection interface is via N/O contacts on the tap changer to terminals 4-10 on the 2V200 as per the wiring diagram on page 1.

The 2V200 provides a powered 7-wire connection to tap changers with either binary or BCD voltage free N/O contacts. Two links (J17 & J18), on the 2V200 PCB are used to change the configuration from BCD input (Factory default) to binary input.

2V164 Voltage Regulator Relay Configuration

The 2V164 VRR must be programmed for DIGITAL TPI operation. The number of tap positions is not set.

VOLTAGE DIVIDER RESISTOR TOLLERANCE

The maximum tolerance of the resistors used in the voltage divider string is determined by the following formula:

$\% \text{ Tolerance} = \frac{100}{3T}$ where T = The maximum tap number.

Resistors with a minimum 1% tolerance rating are recommended.

AUXILIARY POWER SUPPLY

110V AC or 240V AC

POWER CONSUMPTION

<6VA at scale maximum current

FREQUENCY OUTPUT

5KHz maximum

TAP RANGE

Suits tap changers with 10 to 30 taps

TAP CHANGER INTERFACE

2V200 connection options: Voltage divider, BCD or binary.
 2V200 generated drive voltage: 50V DC

OPERATING TEMPERATURE RANGE

-5 to 70 degrees C

TRANSIENT OVERVOLTAGE

Between independent circuits without damage or flashover

IEC60255-5 CLASS III

5kV 1.2/50us 0.5J

INSULATION COORDINATION

Between independent circuits
 Across normally open contacts

IEC60255-5 CLASS III

2.0kV RMS for 1 minute
 1.0kV RMS for 1 minute

HIGH FREQUENCY DISTURBANCE

2.5kV 1MHz common mode
 1.0kV 1MHz differential mode

IEC60255-22-1 CLASS III

≤ 3% variation

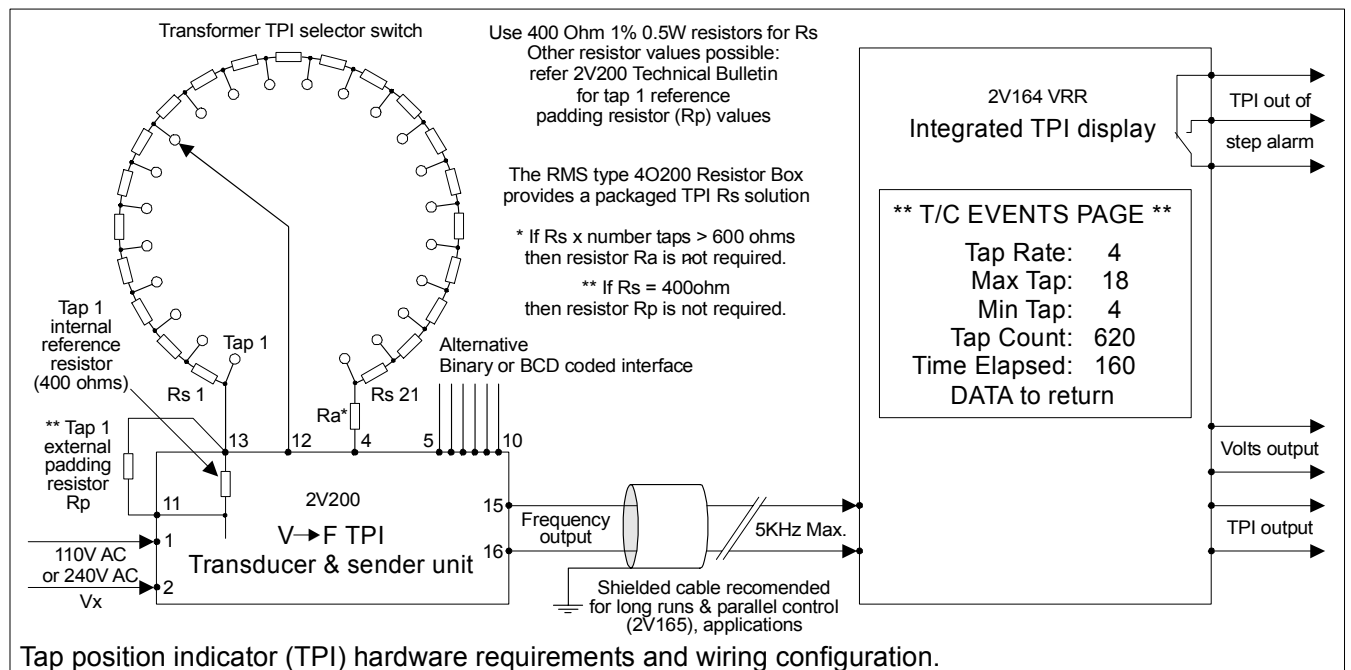

Figure 1 – Application diagram

Australian Content

Unless otherwise stated the product(s) quoted are manufactured by RMS at our production facility in Melbourne Australia. Approximately 60% of our sales volume is derived from equipment manufactured in house with a local content close to 90%. Imported components such as semi-conductors are sourced from local suppliers & preference is given for reasonable stock holding to support our build requirements.

Quality Assurance

RMS holds NCSI (NATA Certification Services International), registration number 6869 for the certification of a quality assurance system to AS/NZS ISO9001-2000. Quality plans for all products involve 100% inspection and testing carried out before despatch. Further details on specific test plans, quality policy & procedures may be found in section A4 of the RMS product catalogue.

Product Packaging

Protection relays are supplied in secure individual packing cardboard boxes with moulded styrene inserts suitable for recycling. Each product & packing box is labeled with the product part number, customer name & order details.

Design References

The products & components produced by RMS are based on many years of field experience since Relays Pty Ltd was formed in 1955. A large population of equipment is in service throughout Australia, New Zealand, South Africa & South East Asia attesting to this fact. Specific product & customer reference sites may be provided on application.

Product Warranty

All utility grade protection & auxiliary relay products, unless otherwise stated, are warranted for a period of 24 months from shipment for materials & labour on a return to factory basis. Repair of products damaged through poor application or circumstances outside the product ratings will be carried out at the customer's expense.

Standard Conditions of Sale

Unless otherwise agreed RMS Standard Terms & Conditions (QF 907) shall apply to all sales. These are available on request or from our web site.



Relay Monitoring Systems Pty Ltd

6 Anzed Court, Mulgrave, Victoria 3170, AUSTRALIA

Tel: 61 3 9561 0266 Fax: 61 3 9561 0277 Email: rms@rmspl.com.au Web: www.rmspl.com.au