

Features

- Local & remote dead line & dead bus selection
- Local minimum line & minimum bus selection
- Sync. check inhibit input
- 10-100 degrees phase angle
- 1-10s sync. check time delay
- Suitable for phase to neutral or phase to phase connection
- Continuous or 2s pulse output
- 40-300V DC auxiliary supply
40-275V AC auxiliary supply
- Optional 20-70V DC supply
- Solid state circuitry (except the electromechanical output relays), providing low burden on the VT
- 4M28 draw out case

Application

The primary application of the 2SY112 is in situations that require verification that synchronism exists prior to closing a circuit breaker to bring a generator on line or re-establish an interconnection between two parts of a power system.

The 2SY112 Series are designed to ensure the two systems are within preset limits of phase angle & voltage prior to circuit breaker closure. The phase angle and sync. check time delay settings are related to the maximum allowable slip frequency as follows:

$$\Delta f = f_1 - f_2 = \frac{1}{t_s} \times \frac{\phi}{180}$$

Synchronism check is also often required in high voltage auto reclosing schemes to allow reclosure of the circuit breakers only if all the synchronising conditions are within the defined limits.

Where a single tie line or bus interconnects two separate systems, one end of the tie is designed to close to energise the dead line, or dead bus, & the other to close onto the live line, or live bus. The 2SY112 series relays are designed to check that conditions of dead line, dead bus, & min. line, min. bus are correct before permitting closure, or reclosure, of the tie.

A separate output from the relay to power a sync. check *IN PROGRESS* output from the auxiliary input voltage is provided to interface with existing systems. A separate inhibit input is provided to cancel a sync. check function due to external events such as protection timing.

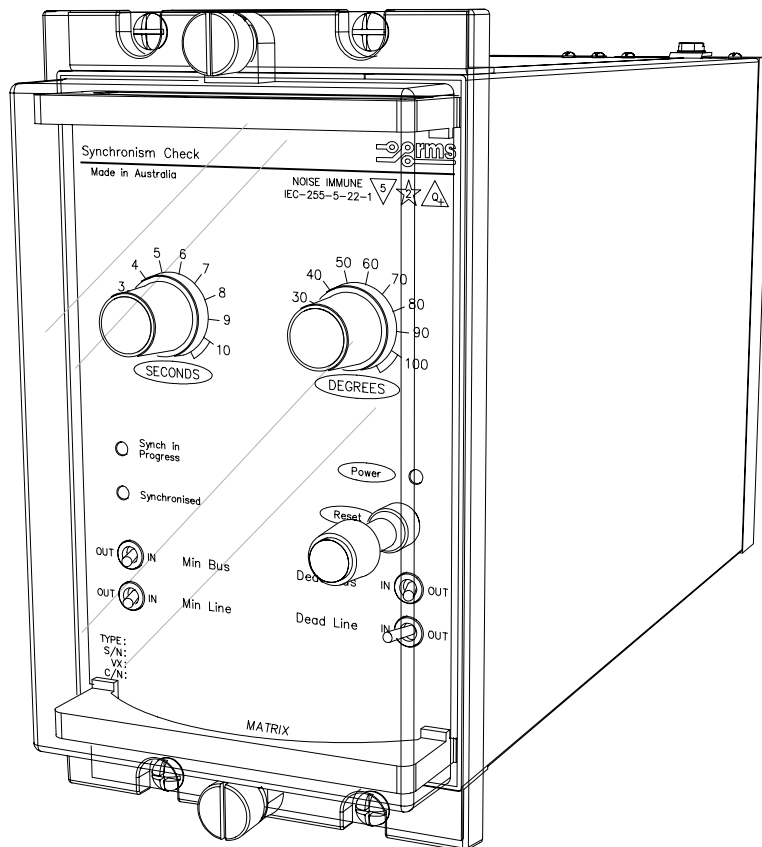

2SY112 depicted in a 4M28 case

Operation

Made in Australia

The 2SY112 synchronism check relay is designed to measure the phase angle between the monitored single phase voltages on the line & bus sides of a breaker & verify that this angle is less than or equal to the front panel setting. If the measured angle has met these criteria for the time period defined by the front panel setting & the voltage magnitudes meet the criteria established by the Dead Line/Bus & Min. Line/Bus settings, the output relay will be energized (Continuous or 2s pulse settings available), & the breaker permitted to close. Resetting will occur if:

1. The front panel reset button is pressed;
2. The remote reset status input is energized;
3. Either the phase angle or voltage magnitude strays outside the pre-set limits;
4. A synchronizing check inhibit signal is applied;
5. The auxiliary supply is removed & the relay re-started.

Front panel mounted LED's provide visual indication of relay status & sync check function.

MINIMUM LINE & MINIMUM BUS SELECTION

Selection of the minimum line or minimum bus on the front panel will allow circuit breaker closure only provided that the condition: $15\% < \text{MONITORED VOLTAGE} < 80\%$ is met. This is instead of $> 80\%$ of nominal. Phase angle requirements still apply to both settings.

DEAD LINE & DEAD BUS SELECTION

Selection is by means of switches located on the front panel of the relay or remotely via a voltage "high" digital input. Selection of the dead line or dead bus will allow circuit breaker closure only provided that the condition: $\text{MONITORED VOLTAGE} < 15\%$ is met. This is instead of $> 80\%$ of nominal. The phase angle requirements do not have to be met when either the dead line or dead bus function is switched in.

SYNCHRONISING STARTING RELAY

The 2SY112 is fitted with a starting relay which energises the electronic circuitry only after a *START* input voltage (or pulse $> 500\text{ms}$ duration) is applied. The purpose of this function is to minimise the drain on the auxiliary supply when the sync. check relay is not in use. The 2SY112 may also be used in a monitoring mode by continuously applying an auxiliary voltage & linking terminals 3 & 5.



PHASE ANGLE

Setting range: 10-100 degrees continuously adjustable.
 Repeatability: +/-2%
 Accuracy: +/-2.5 degrees

DELAY TIMER

Setting range: 1 to 10 seconds
 Repeatability: +/-2%
 Accuracy: +/-0.5 second

SENSING VOLTAGE

110 volt 50Hz & 63.5 volt 50Hz
 Burden: 1.5VA

AUXILIARY SUPPLY

40-300V DC & 40-275V AC
 Burden : <5W at 110V AC
 <5VA at 110V DC

RELAY START INPUT

Pulse time: 500ms minimum
 Pulse voltage: 40-300V DC & 40-275V AC

STATUS INPUT FUNCTION

The status input function is factory set to inhibit relay operation during the application of a control voltage. Changing a link (LK01), on the PCB can change the status input to operate on the removal of a control voltage.

OUTPUT CONTACTS

Sync. check output: 2 C/O contacts provided
 Relay fail alarm: 1 C/O contact picked up when relay healthy

SYNCHRONISING CHECK OUTPUT FUNCTION

The output contacts are factory set to pick up when the requirements for a synchronizing check output are met and reset only when the relay is reset as described on page 1.

The output contacts may be configured to provide a 2s pulse output by withdrawing the relay module & changing a jumper setting on the control PCB as depicted on the wiring diagram:

It should be noted that the relay must still be reset before a further synchronizing check sequence can be initiated.

OUTPUT CONTACT RATINGS

Make & carry
 30A AC or DC (Limits L/R=40ms & 300V max.) for 0.2s
 20A AC or DC (Limits L/R=40ms & 300V max.) for 0.5s
 5A AC or DC continuously

Break (Limits 5A & 300V max.)
 1,250VA AC resistive
 250VA at 0.4PF AC inductive
 75W DC resistive
 30W DC inductive L/R = 40ms
 50W DC inductive L/R = 10ms

Minimum recommended load
 0.5W, 10mA or 5V minimum.

Technical Data

LINE & BUS SETTING GROUPS

The following table identifies the required voltage parameters for seven (7) *useful* setting groups to achieve a synchronizing check output.

	Switch Setting				Voltage Parameters	
	Min. Line	Min. Bus	Dead Line	Dead Bus	Line Volts V_L	Bus Volts V_B
1	Out	Out	Out	Out	$V_L > 80\%$	$V_B > 80\%$
2	Out	Out	Out	In	$V_L > 80\% *$	$V_B < 15\% *$
3	Out	Out	In	Out	$V_L < 15\% *$	$V_B > 80\% *$
4	Out	Out	In	In	$V_L < 15\% *$	$V_B < 15\% *$
5	Out	In	Out	Out	$V_L > 80\%$	$15 < V_B < 80\%$
6	In	Out	Out	Out	$15 < V_L < 80\%$	$V_B > 80\%$
7	In	In	Out	Out	$15 < V_L < 80\%$	$15 < V_B < 80\%$

Tolerance on all selections: +/-1.5% of nominal input
 * Phase angle parameters do not have to be met for these settings.

INSULATION WITHSTAND

IEC60255-5 2KV RMS & 1.2/50 5KV impulse between:
 ♦ all input terminals & frame
 ♦ all output terminals & frame
 ♦ all input & output terminals
 ♦ each input group
 ♦ each output group

HIGH FREQUENCY DISTURBANCE

IEC60255-22-1 2.5KV 1MHz common mode
 1.0KV 1MHz differential mode

ELECTROSTATIC DISCHARGE

EN61000-4-2:1995 8KV Level 3

RADIO FREQUENCY INTERFERENCE

EN61000-4-3:1995 10V/m Level 3

FAST TRANSIENT DISTURBANCE

EN61000-4-4:1995 4KV Level 4

OPERATING TEMPERATURE RANGE

-5 to +55 degrees Celsius ambient operating temperature range.

CASE

Size 4 draw out
 28 M4 screw terminals
 Flush panel mount or 4U high 1/4 width 19 inch rack mount
 IP51 rating

ACCESSORIES SUPPLIED WITH EACH RELAY

1 x M4 self threading mounting screw kit P/N 290-406-151
 1 x M4 terminal screw kit (28 per kit) P/N 290-407-153
 1 x Product Test Manual

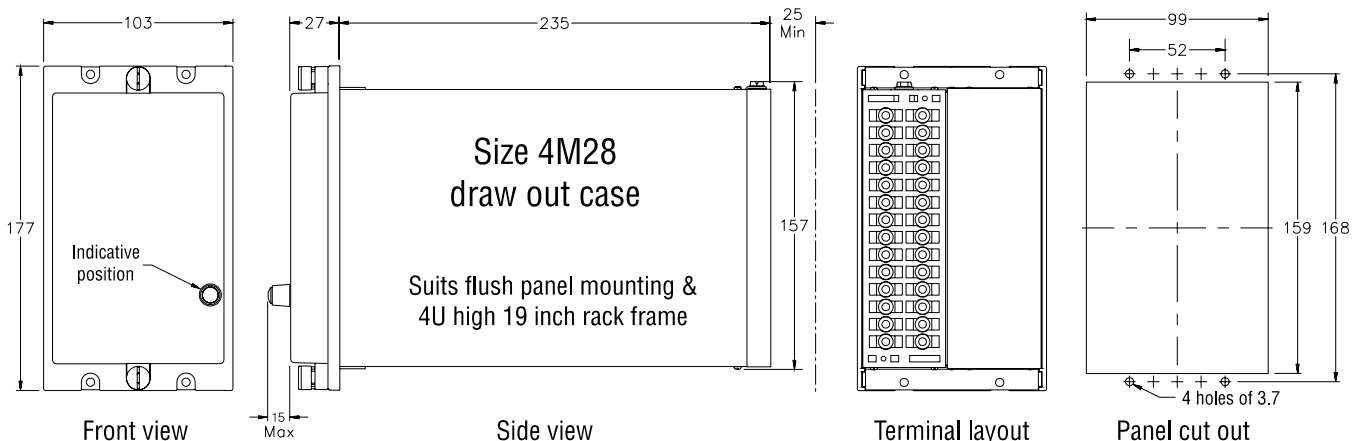

Ordering Information

Generate the required ordering code as follows: e.g. 2SY112 BBD

2SY112 1 2 3 4

1 AUXILIARY SUPPLY RANGE

- A 20-70V DC
- B 40-300V DC / 40-275V AC

2 GROUP 1 STATUS INPUTS (Apply volts to inhibit = default)

- | Opto-isolated input | Relay coil input |
|---------------------|------------------|
| A 24-80V AC/DC | D 12V DC |
| B 75-150V AC/DC | E 24V DC |
| C 150-300V AC/DC | F 48V DC |
| | G 110V DC |

3 REMOTE RESET

- | Opto-isolated input | Relay coil input |
|---------------------|------------------|
| A 24-80V AC/DC | D 12V DC |
| B 75-150V AC/DC | E 24V DC |
| C 150-300V AC/DC | F 48V DC |
| | G 110V DC |

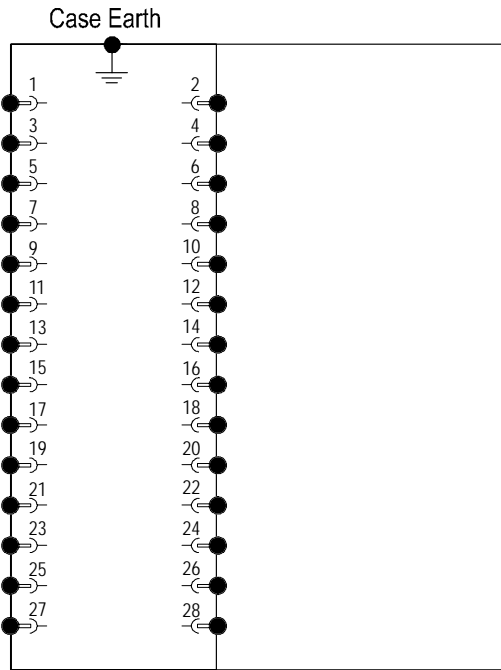

4M28 Case terminations (REAR VIEW)

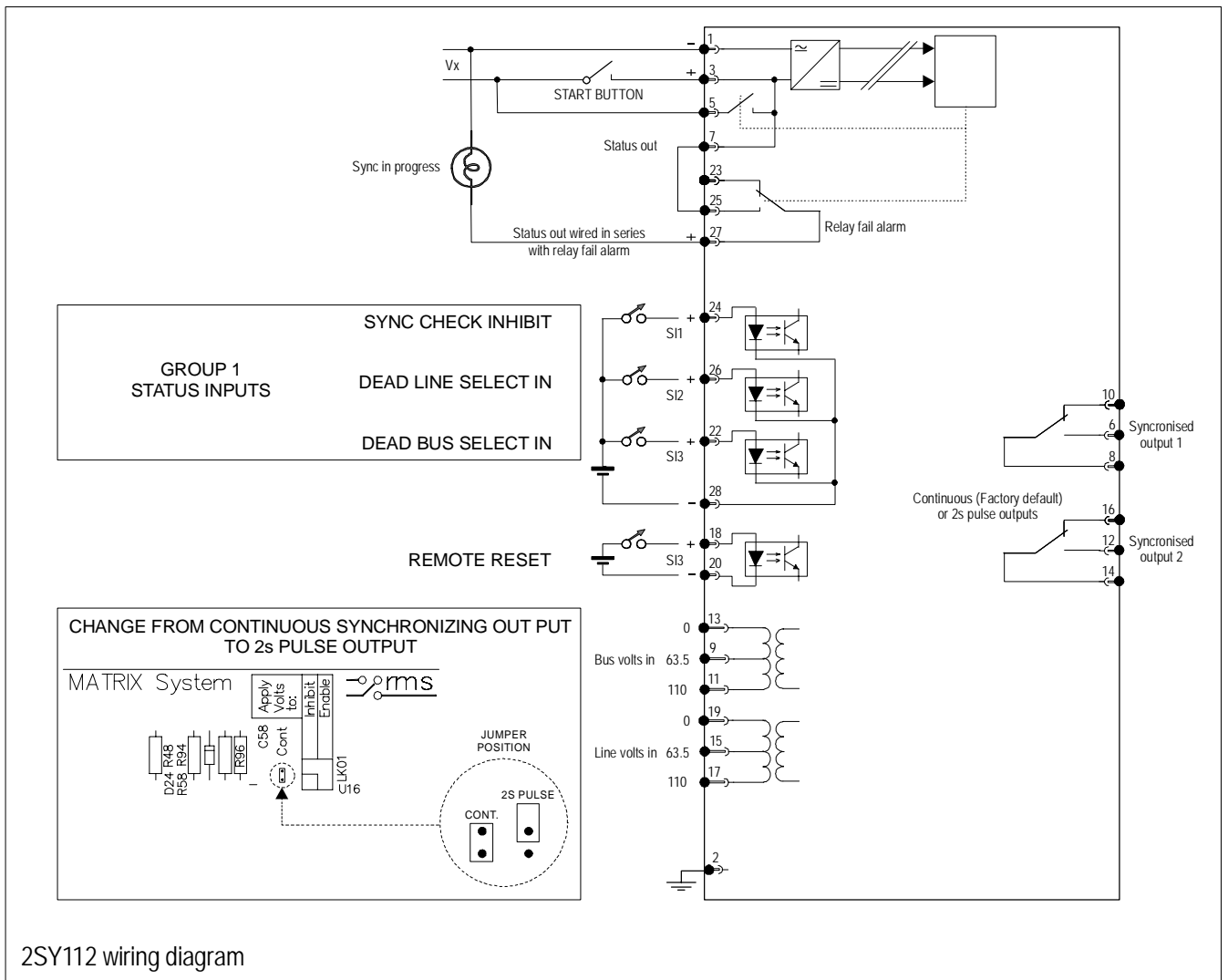

2SY112 wiring diagram

Australian Content

Unless otherwise stated the product(s) quoted are manufactured by RMS at our production facility in Melbourne Australia. Approximately 60% of our sales volume is derived from equipment manufactured in house with a local content close to 90%. Imported components such as semi-conductors are sourced from local suppliers & preference is given for reasonable stock holding to support our build requirements.

Quality Assurance

RMS holds NCSI (NATA Certification Services International), registration number 6869 for the certification of a quality assurance system to AS/NZS ISO9001-2000. Quality plans for all products involve 100% inspection and testing carried out before despatch. Further details on specific test plans, quality policy & procedures may be found in section A4 of the RMS product catalogue.

Product Packaging

Protection relays are supplied in secure individual packing cardboard boxes with moulded styrene inserts suitable for recycling. Each product & packing box is labeled with the product part number, customer name & order details.

Design References

The products & components produced by RMS are based on many years of field experience since Relays Pty Ltd was formed in 1955. A large population of equipment is in service throughout Australia, New Zealand, South Africa & South East Asia attesting to this fact. Specific product & customer reference sites may be provided on application.

Product Warranty

All utility grade protection & auxiliary relay products, unless otherwise stated, are warranted for a period of 24 months from shipment for materials & labour on a return to factory basis. Repair of products damaged through poor application or circumstances outside the product ratings will be carried out at the customer's expense.

Standard Conditions of Sale

Unless otherwise agreed RMS Standard Terms & Conditions (QF 907) shall apply to all sales. These are available on request or from our web site.



Relay Monitoring Systems Pty Ltd

6 Anzed Court, Mulgrave, Victoria 3170, AUSTRALIA

Tel: 61 3 9561 0266 Fax: 61 3 9561 0277 Email: rms@rmspl.com.au Web: www.rmspl.com.au